

广东库博精密科技集团股份有限公司

GUANGDONG UNIHOPPER PRECISION TECHNOLOGY
CROUP CO.,LTD

运营中心：广州市天河区天河路 242 号丰兴广场 B 栋 2404 室
Operating center: Rm2404 Building B, Fengxing Plaza, No.242,
Tianhe Rd, Tianhe District, Guangzhou City

总部：肇庆高新技术产业开发区创业路 9 号库博工业园
Headquarter: Unihopper industrial park, No.9 Chuangye
road, High-tech Industrial Development Zone ,Zhaoqing City,
Guangdong Province, China

TEL: 0758-3212900/3212901
FAX: 0758-3212902
E-mail: sales@unihopper.biz

www.unihopper.biz

2303-10K



公众号



微官网

库博五金保留在不影响功能质量前提下，适当改动尺寸、外型而不另行通知。实际产品会因印刷原因与样本上有少许色差，产品图片尺寸误差以实物为准
On the premise of not influence the function and uality,Grasshopper reserves the right of changing the size,outlook without notice.
There will be a little color difference between the product in presswork and definite object.The correct size of the product subject to definite object.

WARDROBE



WARDROBE 衣柜五金产品手册

WARDROBE

更懂高端家居的五金品牌

More understanding of high-end home hardware brands

库博衣柜五金产品手册



Unihopper Intelligent industrial park
库博智能化工业园

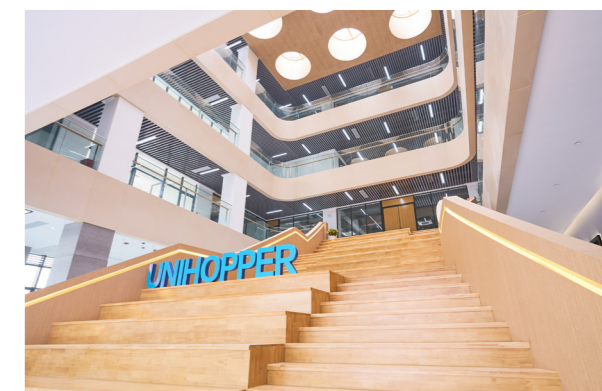

Unihopper R & D Building
库博研发大楼

MILESTONES

品牌里程碑

2003

Unihopper founded the company in Guangzhou, and launch the first generation one-way soft closing drawer box.

库博在中国广州成立销售公司
推出第一代单缓冲骑马抽

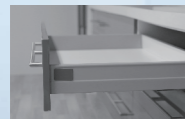

2007

Unihopper founded a union design group with designers from Europe and Columbia, and successfully launch the second generation two-way soft closing drawer box. The concept of two-way soft closing became popular around world ever since.

与欧洲、哥伦比亚设计师成立联合设计小组
推出第二代双缓冲骑马抽
双缓冲理念在此风靡全球



2005

Unihopper decided to invest with the advanced technology from Europe and construct the production base in FOSHAN of China.

投建佛山生产基地
引进欧洲先进技术在中国进行生产

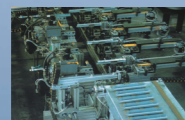

2010

Unihopper successfully researched and developed the third generation interactive two-way soft closing drawer box and synchronize conceal slide.

研发第三代联动双缓冲骑马抽
同步隐藏导轨

2008

Unihopper set up the marketing center and began to provide quality products and service for Chinese furniture customers.

组建营销中心
为中国家具客户
提供优质的产品和服务

2015

Unihopper successfully researched and developed the fifth generation interactive two-way soft closing drawer box-Magic box, and successfully hosted the "Night of Unihopper" in Beijing wardrobe annual conference.

第五代联动双缓冲骑马抽 - 魔力抽
北京衣柜年会举办“库博之夜”



2013

The union design group successfully researched and developed basket and wardrobe storage system (MOKA).

研发拉篮
衣柜收纳系统(摩卡系列)



2017

Unihopper successfully hosted the second "Unihopper summit conference". Same time, Unihopper Business College was founded.

第二届全球峰会
库博商学院成立

2016

Unihopper successfully hosted "Unihopper summit conference" in Guangzhou, and announced Unihopper would globalize the brand.

在广州举办库博峰会
UNIHOPPER 库博全球化

2019

Unihopper successfully hosted the third "Unihopper summit conference", and founded the new Unihopper production base and Unihopper brandday. Same year, Unihopper researched and developed the Phantom kitchen storage system and Co-box.

第三届全球峰会
新生产基地奠基
库博“9月9日品牌日”成立
研发魅影系列厨房收纳、酷力抽系列



2020

Unihopper become one of the home decoration drafting committee for Hinge, slide and basket. In the same year, Unihopper won the National High-tech Enterprise. Vanka, COKA have been introduced to the market.

成为全装修家居五金铰链、导轨、拉篮
使用标准起草单位
荣获国家高新技术企业
梵卡、酷卡系列推向市场



2021

Unihopper new production base put into use officially. LINA, HUGGEN have been introduced to the market.

新产业园正式投入使用丽影、库格系列新品推出



2022

Unihopper international R&D center and the flagship showroom in the new headquarters fully open to the public, same time, Unihopper establish product R&D centre and product laboratory together with Vanke caizhu.

库博国际研发中心与
新总部旗舰产品体验厅开放
与万科采筑共建产品研发中心、
产品国家实验室

2023

We held the first "Unihopper Cup" National Terminal Designers Competition, initiating the first action in the Industry by making a solid sound for the professional home designers who stand as a group of product end-user

库博举办首届“库博杯”全国终端设计师大赛,开创行业新举,为家居业终端设计师发声。

BRIEF INTRODUCTION

集团介绍

Unihopper, a high-end customized home brand and the provider for comprehensive solutions of hardware supporting, implements the "Belt and Road" global development strategy to develop the global market. Offering the Uni-products, Uni-design, and Uni-service to every corner of the world.

After years of development, Unihopper has sole agents in dozens of countries and regions around the world, such as Netherlands, Canada, Russia, Slovenia, Argentina, Korea, Iran, Spain, Portugal, Ireland, Saudi Arabia, Colombia, South Africa, India, Southeast Asia Regions and China HongKong, Macao and Taiwan regions and so on; and now, Unihopper has become a major suppliers for many well-known cabinet and home brands in the world. In China, many listed furniture enterprises are our Uni-partners including OPPEIN, PIANO, SOGAL, ZBOM, Haier, OLO and so on. At the same time, Unihopper is also the major suppliers of Vanke, LONGFOR, POLY, China Overseas and many other real estate companies in China.

In 2005, Unihopper set up a production base and established a large storage center in Nanhai city in China, and a new intelligent Uni-industrial park of more than 120,000 square meters will also be put into use in 2021. As one of the best name and provider for the high-end customized furniture hardware industry, Unihopper has always upheld the brand values of "European quality, Chinese price", and now, has become a leading brand popularizing in many home furnishing companies and consumers all over the world. In the future, Unihopper will increase more investment in space enlarging, strengthen multi-dimensional development including product application, intelligent scene introduction, online and offline channel integration, striving to become the best home storage master around consumers' life.

Unihopper 库博是一家致力于全球化发展的定制家居五金及五金配套解决方案的供应商。库博实行“一带一路”全球发展战略，开放的胸怀开拓全球市场。将库博的产品、文化、理念推广到世界每个角落。

经过多年的发展，UNIHOPPER 库博在荷兰、加拿大、俄罗斯、斯洛文尼亚、阿根廷、韩国、伊朗、西班牙、葡萄牙、爱尔兰、沙特、哥伦比亚、南非、印度、东南亚地区以及中国港澳台地区等全球数十个国家和地区设有独家代理，现已成为全球众多知名橱柜和家居品牌的主要供应商。在华许多上市家居企业均是库博合作伙伴，包括有：欧派、索菲亚、志邦、海尔、我乐等，同时库博品牌也是万科、龙湖、保利、中海等众多地产公司的主要供应商。

2005年，Unihopper 库博在中国佛山南海设立了生产基地并建立了大型仓储中心。全新超12万平方米智能化库博工业园已在2021年投入使用。作为一家高端定制家居五金供应商，Unihopper 库博一直坚持原创设计，“价格不上，品牌不下”的营销理念，已然成为全球众多家居企业和消费者追随的行业领导品牌，未来库博集团将加大更多空间投入，将产品运用、智能化场景导入、线上线下通道一体化等多维度发展，努力打造成为消费者身边最出色的家居收纳大师。



德国GS质量检测认证
GS Quality Test
Certification



英国皇家ISO9001
质量管理认证
ISO 9001 Quality
Management Certification



国家高新技术企业
National High-
Tech Enterprise



家居五金铰链、抽屉导轨、拉篮
地产精装集团标准主起草单位
Standards Maker of Kitchen
Hardware Industry



共建研发中心
共建产品实验室 (CNAS)
R&D center and product
laboratory

COMPANY VISION

库博的理念

企业使命
CORPORATE MISSION:

满足人们对美好生活的向往是库博人的使命追求
To meet people's yearning for a better life is the mission
pursuit of Unihopper

价值观
VALUES:

诚信、利他、奋斗、创新、理解、共进
Integrity, altruism, struggle, innovation, understanding,
common progress

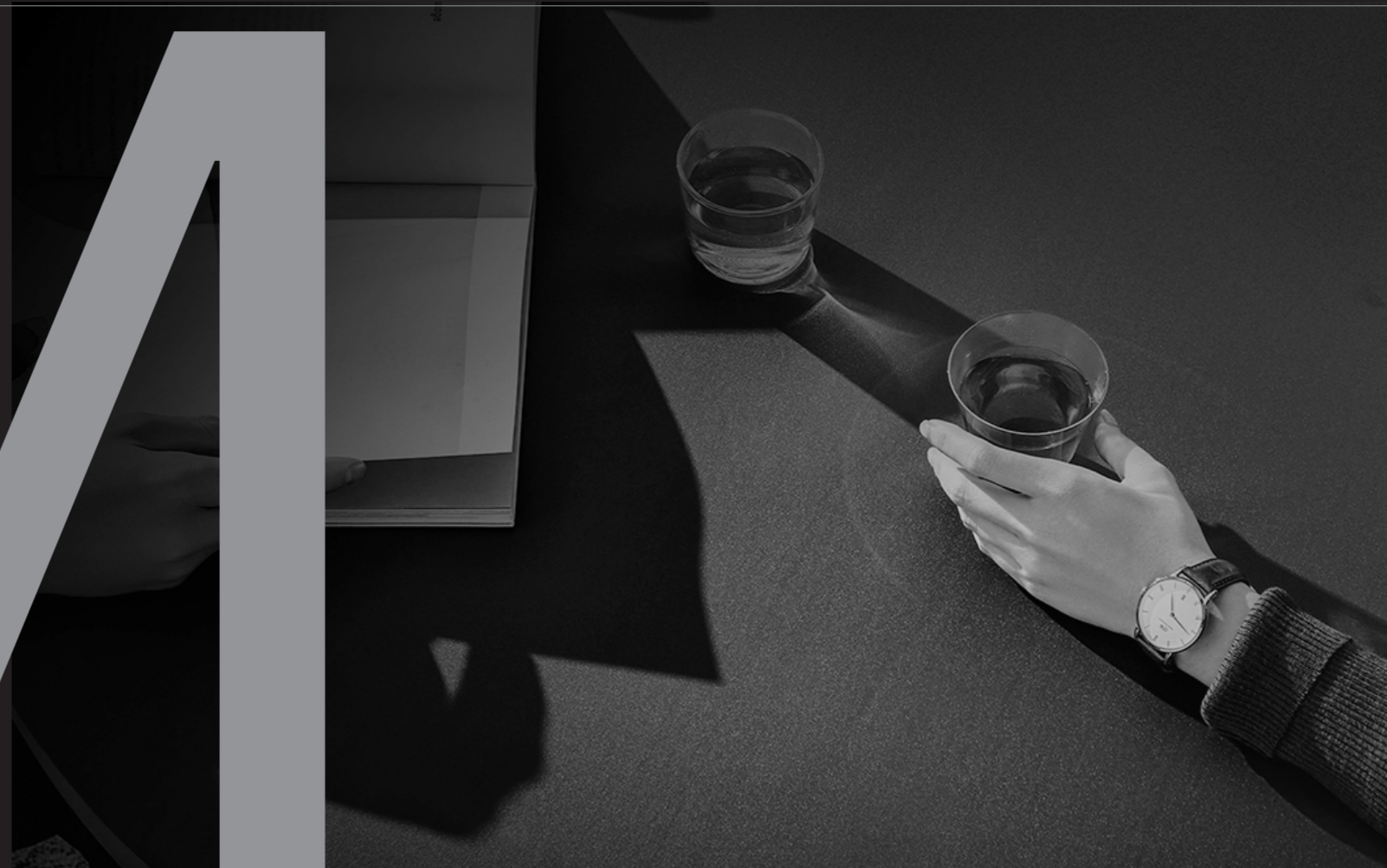

MONIKA STORAGE SYSTEM

摩尼卡衣柜收纳系统



NOBILITY IS NOT MATERIAL LUXURY, BUT A REFINED ATTITUDE TO LIFE.

高雅与实用的结合，为所有物品提供完美的收纳方式，使衣柜透出优雅气质。



MONIKA STORAGE SYSTEM

MONIKA COMBINES ELEGANCE WITH PRAGMATISM TO MEET ALL EXPECTATIONS OF QUALITY LIFE AND IS THE WAY WE HAVE LONG LOOKED FORWARD TO IT.

高贵不是物质的奢华，而是一种精致的生活态度。摩尼卡系列将优雅格调与实用主义完美融合，满足对品质生活的所有期望，是我们憧憬已久的生活方式。





MONIKA /
Leather flat storage box

→ 摩尼卡皮革平板收纳篮

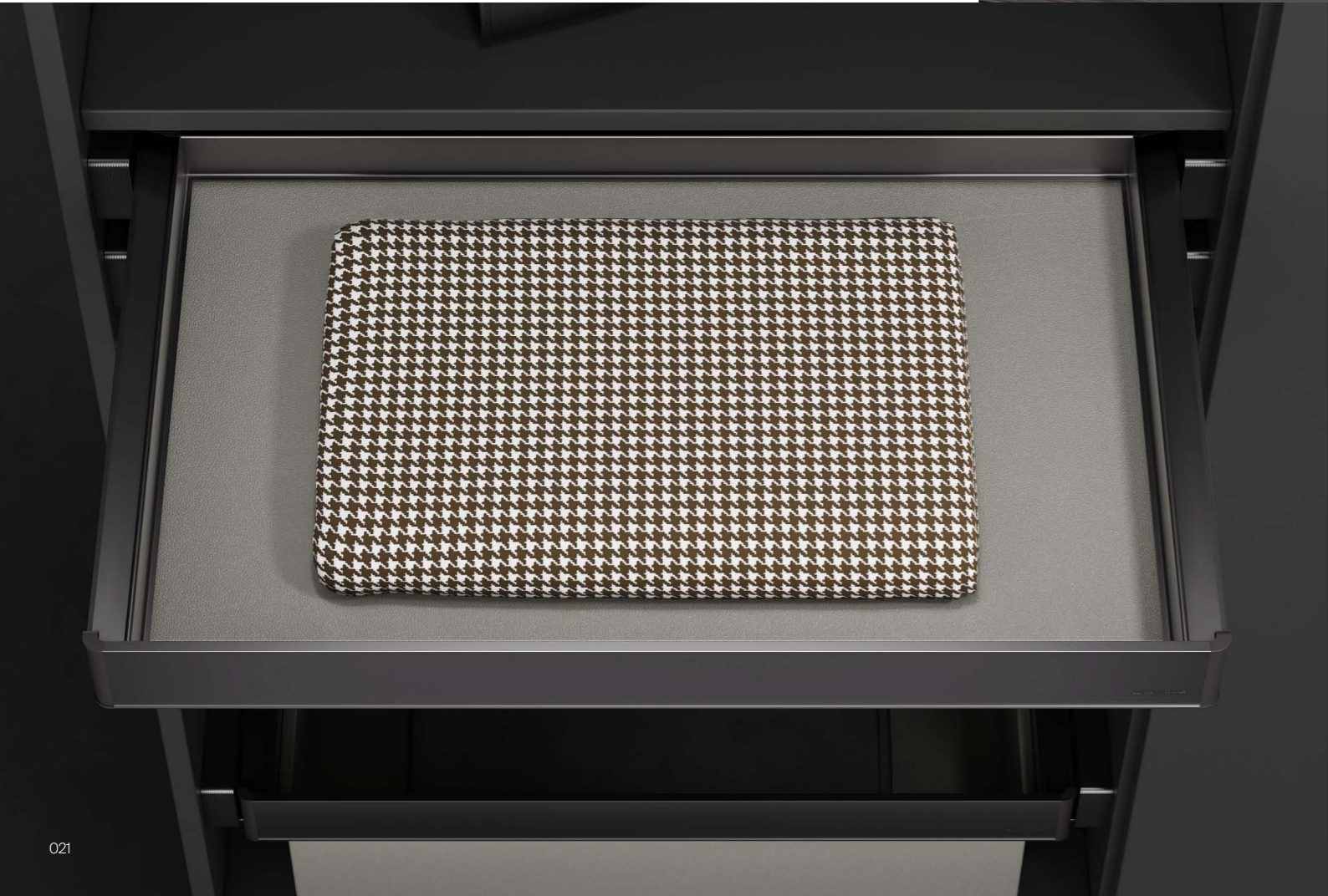



MONIKA /
Leather multifunctional storage box

→ 摩尼卡皮革饰品收纳盒



EXTRAORDINARY VISUAL ENJOYMENT WITH
FUNCTIONAL AND STYLISH DESIGN, TO
STORE THE JEWELRY PERFECTLY.

高雅时尚，非一般的视觉享受。丰富的收纳功能，足够
您收纳一切所需物品，兼顾了实用性和舒适性，只将最
美好的一面展现给你。



The beauty of orderliness.

“It feels like a luxury touch”, the elegant design is not restricted by any times and tide, but makes your wardrobe full of charming.

“可以触摸的奢华”，高雅的设计不受任何时代与潮流限制，别于世俗眼光的风采，使您的衣橱充满魅力。





THE TROUSERS RACK WITH ANTI-SLIP DESIGN, KEEP THE PANTS ORDERLY AND MAKE IT EASY FOR TAKING.

分隔裤架设计，不仅扩大收纳空间，而且拿取方便。加粗挂条设计，裤子不易掉落，不易起折痕，让您的裤子保持熨烫之后得笔直与整洁。

MONIKA /
Trousers rack

→ 摩尼卡裤架





MONIKA /
Trousers rack

→ 摩尼卡裤架



MONIKA /
Leather underwear storage box

→ 摩尼卡皮革内衣收纳篮

THE LEATHER STORAGE BOX KEEPS YOUR UNDERWEAR A PERFECT STORAGE.
分类收纳设计，细心呵护贴身衣物，品质生活由内而外，细腻的触感带来极致的生活愉悦感。



LIFE HAS A THOUSAND
KINDS OF ATTITUDE.





MULTI-FUNCTIONAL AND CABINET-STYLED DESIGN IS UTILITY TO MAKE GOOD USE OF THE WARDROBE SPACE.
多功能收纳充分利用衣柜空间，入柜式设计，低调又不失奢华，达到一种极致生活体验。

MONIKA /
Leather storage bag

→ 摩尼卡皮革收纳篮



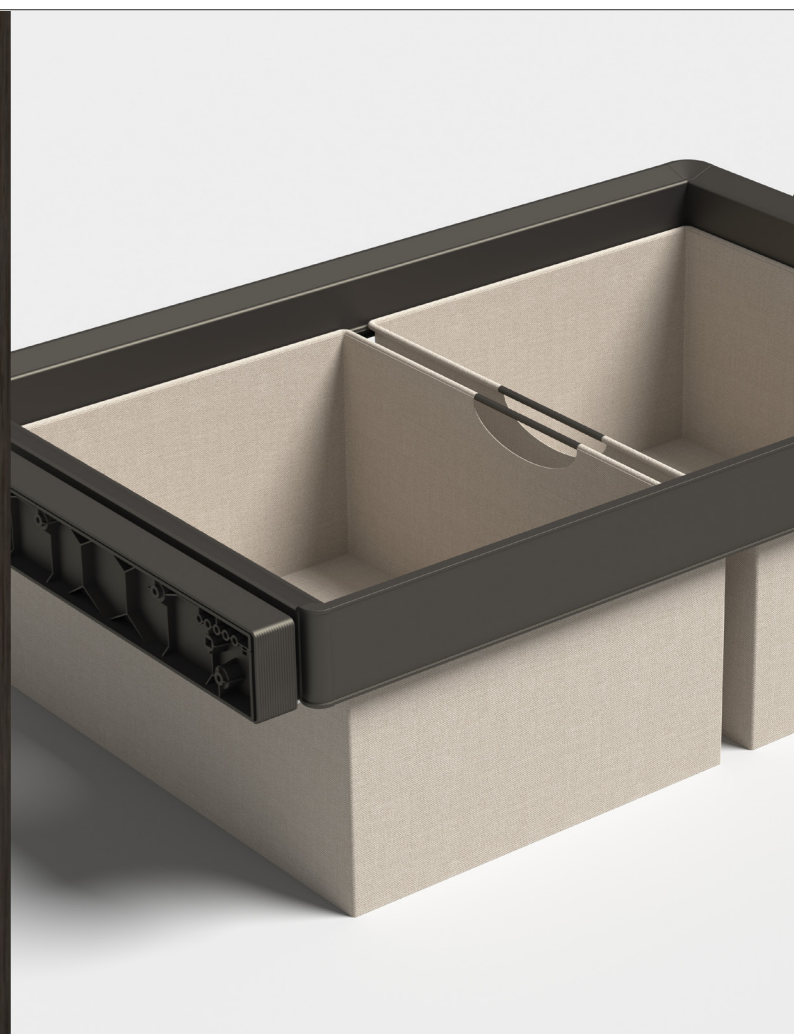

MONIKA /
Laundry bag

→ 摩尼卡麻布收纳篮

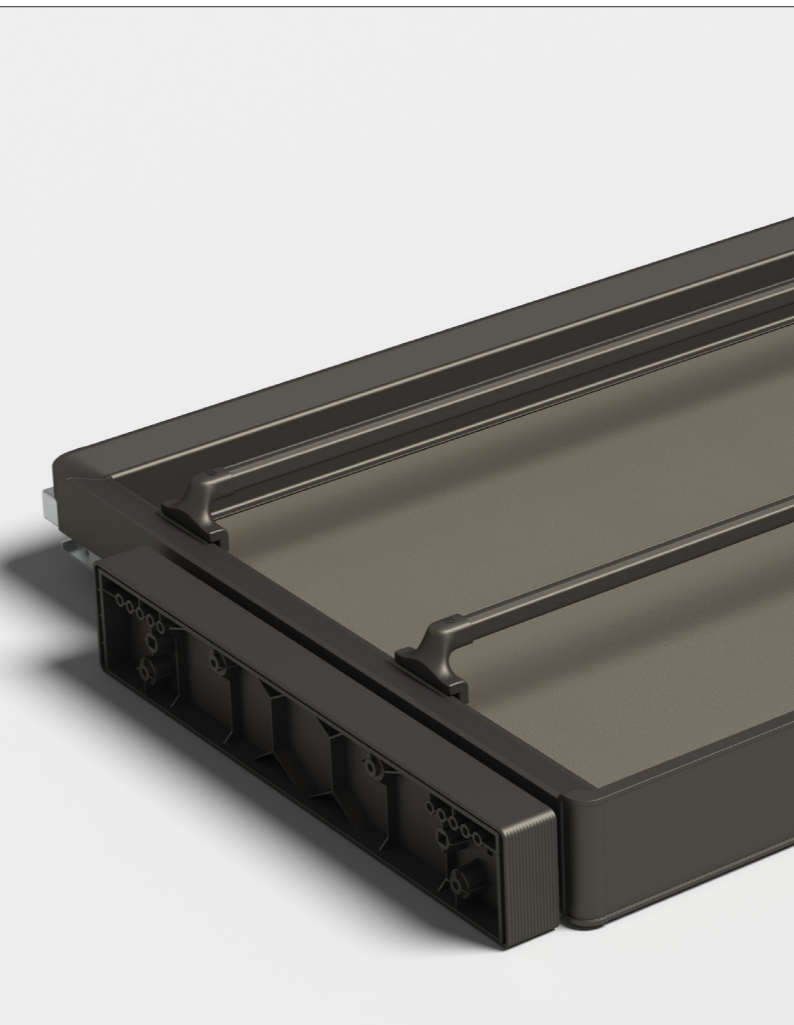

MONIKA /
Shoes rack

→ 摩尼卡鞋架





→ FEATURES / 产品特点

- Easy clip on way, free from most of the hinges

经典 U 型快装结构, 门铰避让设计, 无惧一切空间的影响

- The upgrade to Gun Grey color, adding the metallic to the whole product. Arc edge design, displaying the beauty of industrial design

框架颜色升级, 让产品整体更具金属感, 整体弧边设计, 展现工业设计的线条美感

- Color: Gun Grey
颜色: 枪灰色 (GG)

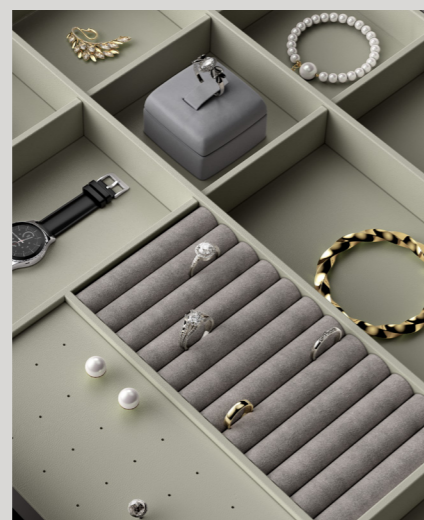

MONIKA LEATHER FLAT STORAGE BOX
摩尼卡皮革平板收纳篮

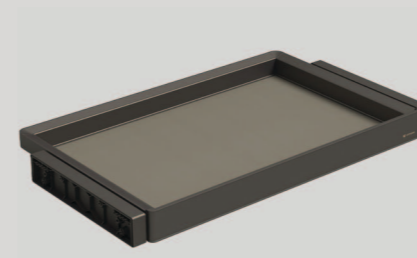

MODEL 型号	CABINET 柜体 W (mm)	WIDTH x DEPTH x HEIGHT (mm) 宽 x 深 x 高 (mm) . 含导轨
WS4183S.060.GG	600	562~582x457x67
WS4183S.070.GG	700	662~682x457x67
WS4183S.080.GG	800	762~782x457x67
WS4183S.090.GG	900	862~882x457x67

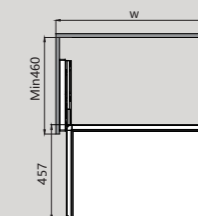

MONIKA LEATHER MULTIFUNCTIONAL STORAGE BOX
摩尼卡皮革饰品收纳盒

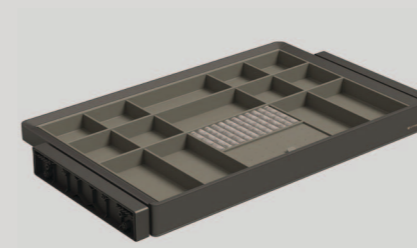

MODEL 型号	CABINET 柜体 W (mm)	WIDTH x DEPTH x HEIGHT (mm) 宽 x 深 x 高 (mm) . 含导轨
WS4184S.060.GG	600	562~582x457x67
WS4184S.070.GG	700	662~682x457x67
WS4184S.080.GG	800	762~782x457x67
WS4184S.090.GG	900	862~882x457x67

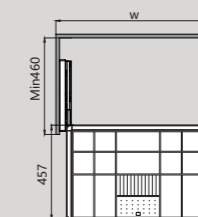

MONIKA TROUSERS RACK
摩尼卡裤架



MODEL 型号	CABINET 柜体 W (mm)	WIDTH x DEPTH x HEIGHT (mm) 宽 x 深 x 高 (mm) . 含导轨
WS4185S.060.GG	600	562~582x457x67
WS4185S.070.GG	700	662~682x457x67
WS4185S.080.GG	800	762~782x457x67
WS4185S.090.GG	900	862~882x457x67

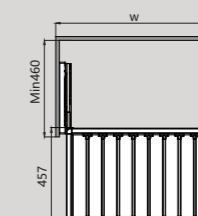

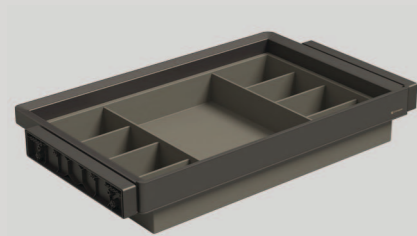

MONIKA LEATHER UNDERWEARE STORAGE BOX
 摩尼卡皮革内衣收纳篮

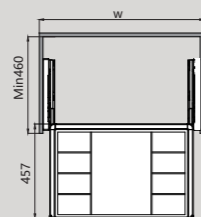
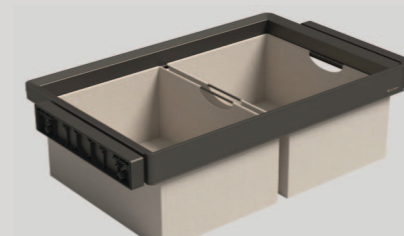
MODEL 型号	CABINET 柜体 W (mm)	WIDTH x DEPTH x HEIGHT (mm) 宽 x 深 x 高 (mm) . 含导轨
WS4186S.060.GG	600	562~582x457x124
WS4186S.070.GG	700	662~682x457x124
WS4186S.080.GG	800	762~782x457x124
WS4186S.090.GG	900	862~882x457x124

MONIKA LAUNDRY BAG
 摩尼卡麻布收纳篮

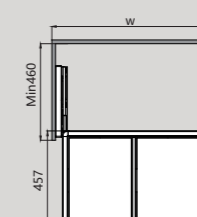
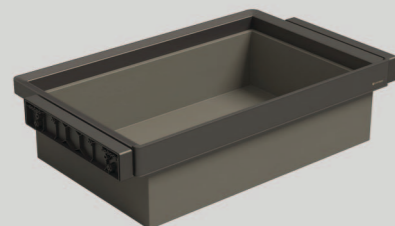
MODEL 型号	CABINET 柜体 W (mm)	WIDTH x DEPTH x HEIGHT (mm) 宽 x 深 x 高 (mm) . 含导轨
WS4188S.060.GG	600	562~582x457x224
WS4188S.070.GG	700	662~682x457x224
WS4188S.080.GG	800	762~782x457x224
WS4188S.090.GG	900	862~882x457x224

MONIKA LEATHER STORAGE BAG
 摩尼卡皮革收纳篮

MODEL 型号	CABINET 柜体 W (mm)	WIDTH x DEPTH x HEIGHT (mm) 宽 x 深 x 高 (mm) . 含导轨
WS4187S.060.GG	600	562~582x457x196
WS4187S.070.GG	700	662~682x457x196
WS4187S.080.GG	800	762~782x457x196
WS4187S.090.GG	900	862~882x457x196

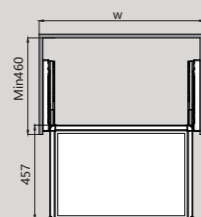
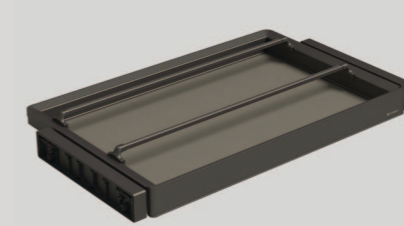
MONIKA SHOES RACK
 摩尼卡鞋架

MODEL 型号	CABINET 柜体 W (mm)	WIDTH x DEPTH x HEIGHT (mm) 宽 x 深 x 高 (mm) . 含导轨
WS4189S.060.GG	600	562~582x457x80
WS4189S.070.GG	700	662~682x457x80
WS4189S.080.GG	800	762~782x457x80
WS4189S.090.GG	900	862~882x457x80

